

## FLT-1S/1F | Ball Float Type Steam Trap

- For Application to larger capacity than thermodynamic trap such as heat exchanger, dryer, chemical plant, and various steam systems. Excellent durability of stainless steel disc, seat, and ball float. Inbuilt air vent assembly to eliminate air-binding.
- All parts are installed at the bonnet, and the integral bonnet would be helpful for easy maintenance.



FLT-1S

FLT-1F

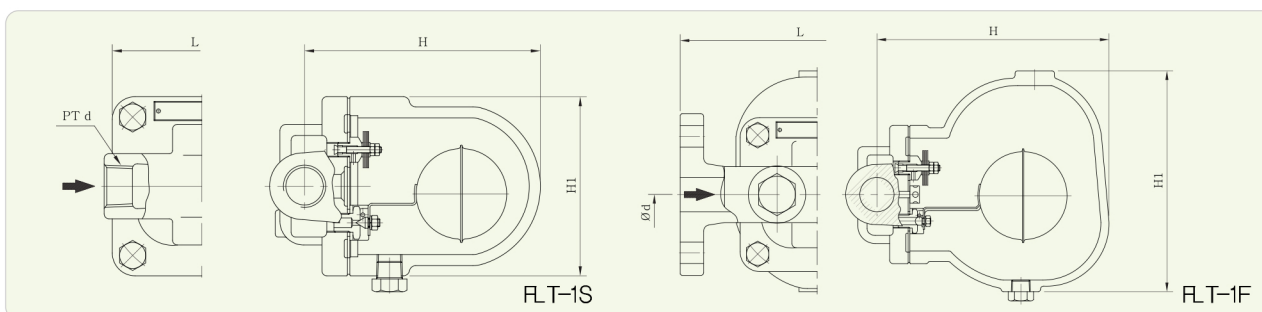

### ► Specifications

Working Pressure	Max. 4.5, 10, 14 kgf/cm <sup>2</sup>
	Min. 0.35 kgf/cm <sup>2</sup>
Working Temperature	Max. 220°C
Connection	FLT-1S : PT Screwed
	FLT-1F : JIS Flanged
Materials	Body : Ductile Iron
	Trim : Stainless Steel

### ► Dimensions

Model	Size	d	L	H1	H	Connection
FLT-1S	15A	PT 1/2"	120	110	155	PT Screwed
	20A	PT 3/4"	120	110	155	
	25A	PT 1"	120	185	190	
	32A	PT 1 1/4"	270	240	295	
	40A	PT 1 1/2"	270	240	295	
	50A	PT 2"	300	260	310	
FLT-1F	15A	15	200	110	170	JIS 10K Flanged
	20A	20	200	110	170	
	25A	25	215	185	190	
	32A	32	320	240	295	
	40A	40	320	240	295	
	50A	50	360	260	310	

